

# Nova C Series Add Ons

## Manual



Green Furniture Concept

## Index

Product description.....	p1-2
Recycling .....	p3
Assembly instructions   Nova C Back Armrest .....	p4
Assembly instructions   Nova C Bench Armrest .....	p5
Assembly instructions   Nova C Table .....	p6
Assembly instructions   Nova C Endpiece Double .....	p7-10
Assembly instructions   Nova C Endpiece Singel .....	p11-13
Assembly instructions   Nova C Endpice Charger Cover Plate .....	p14
Assembly instructions   Radius Charger .....	p15-16
Electrical instructions   Radius Charger.....	p17-21
Assembly instructions   Food & Beverage Armrest.....	p22
Electrical instructions   Food & Beverage Armrest Charger.....	p23-27

**Nova C Back Armrest**

Nova C Back Armrest can be placed in any slender rib of Nova C Back, Nova C Wall, or Nova C Double. The default location is in the center of the bench module.

Material: Powder coated steel.

**Nova C Table**

The Nova C Table can be placed in any slender rib of Nova C Back, Nova C Bench, Nova C Wall or Nova C Double. The default location is in the center of the bench.

Material table top: Massive oak treated with hardwax oil.

Material table holder: Powder coated steel.

**Nova C Bench Armrest**

Nova C Bench Armrest can be placed in any slender rib of the Nova C bench. The default location is in the center of the bench module.

Material: Powder coated steel.





### Radius Charger

Nova Charger can be placed on any leg of Nova C Bench, Nova C Back or Nova C Back Double. Choose between your preferred combination of outlets and/or USB.

Material casing: Powder coated steel.

Material outlet: ABS

### Nova C Food & Beverage Armrest

Nova C Food & Beverage Armrest can be placed in any end rib of the Nova C bench.

Material table top: Massive oak treated with hardwax oil.

Material table holder: Powder coated steel.

Material outlet: ABS





Ribs and table tops are made of wood and adhesive and are sorted as combustible.

Legs, strips, armrest, table holder and small parts are made of steel and are sorted as metal.



Glides are made of HDPE and are sorted as plastic.

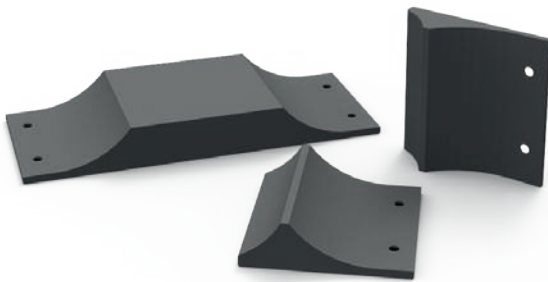

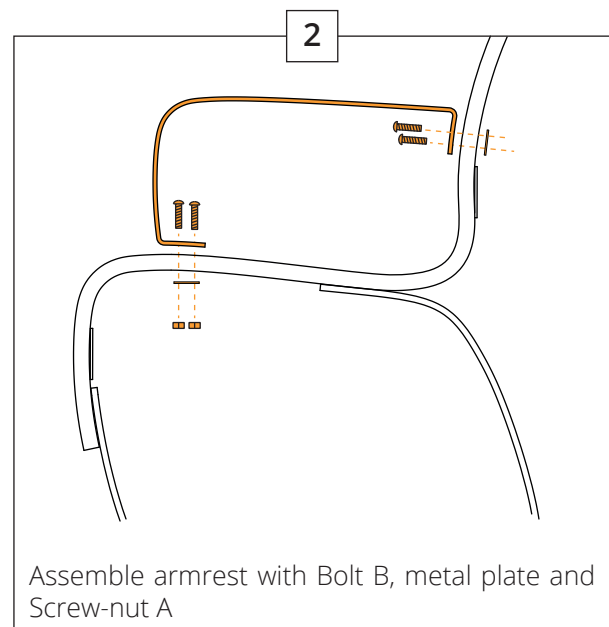
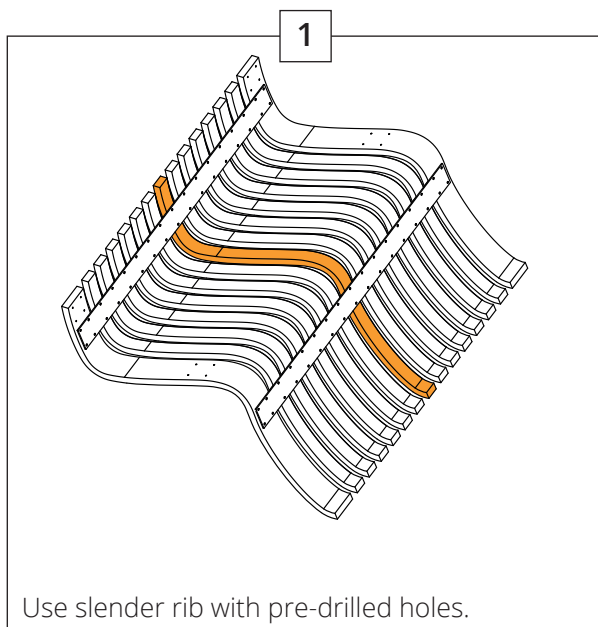
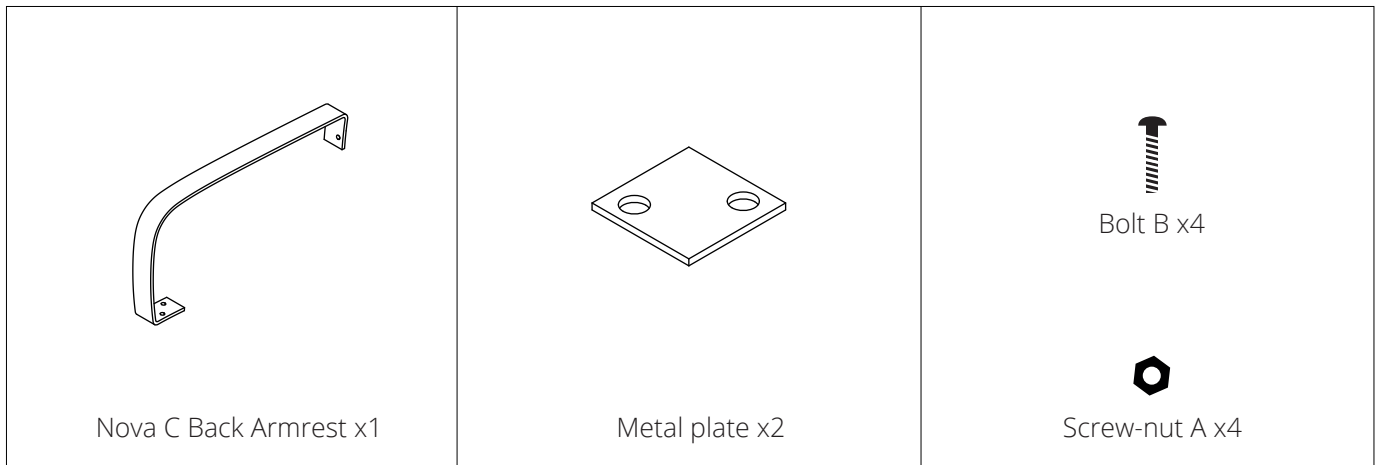

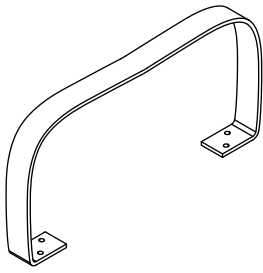

Nova C Bench Armrest x1

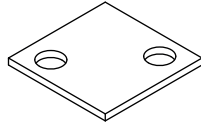

Metal plate x2



Bolt B x4



Screw-nut A x4

1

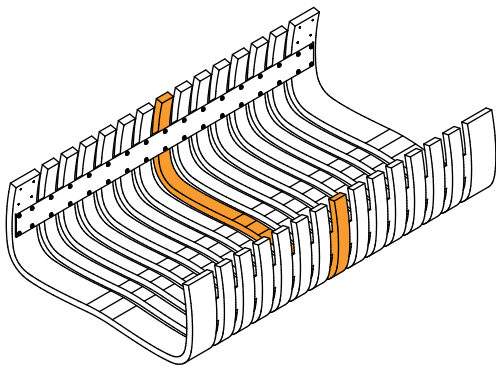

Use slender rib with pre-drilled holes.

2

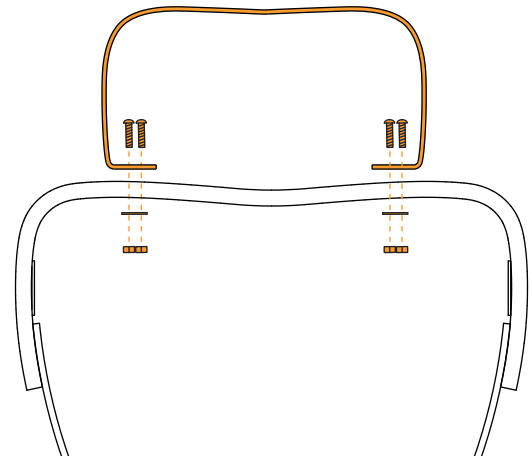

Assemble armrest with Bolt B, metal plate and Screw-nut A

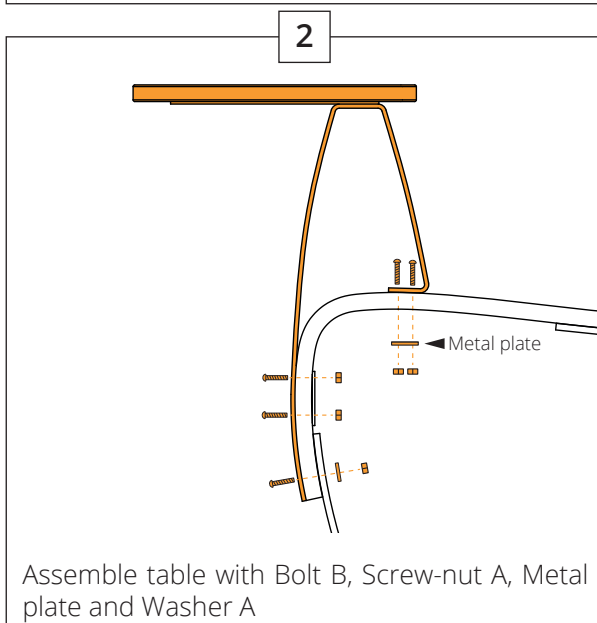
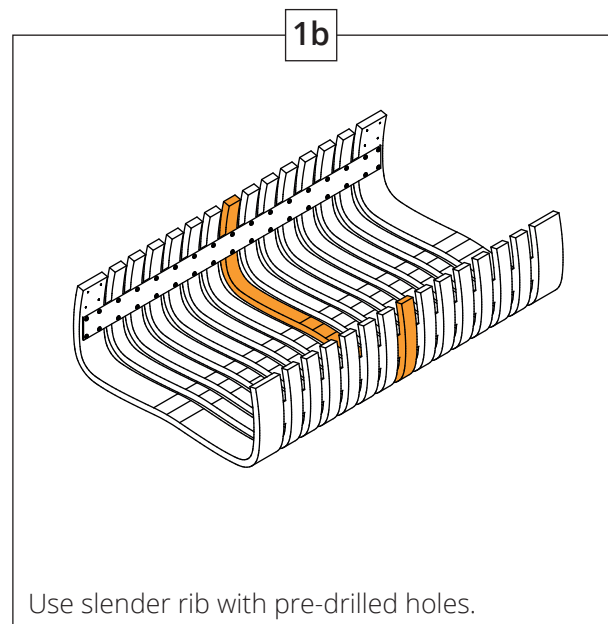
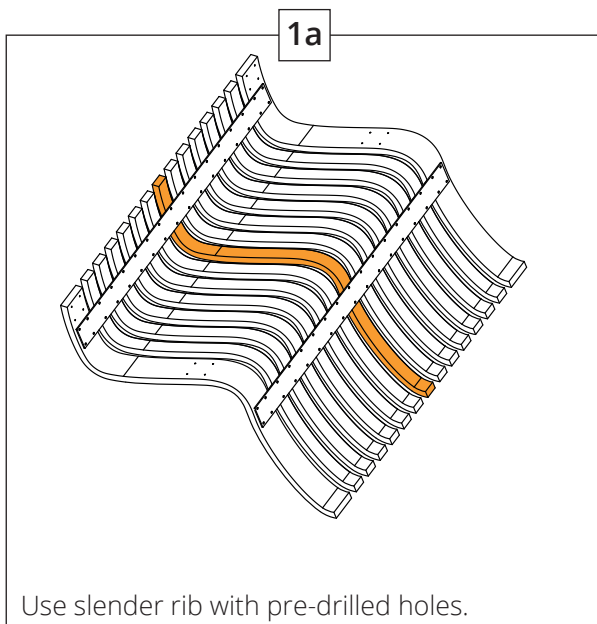
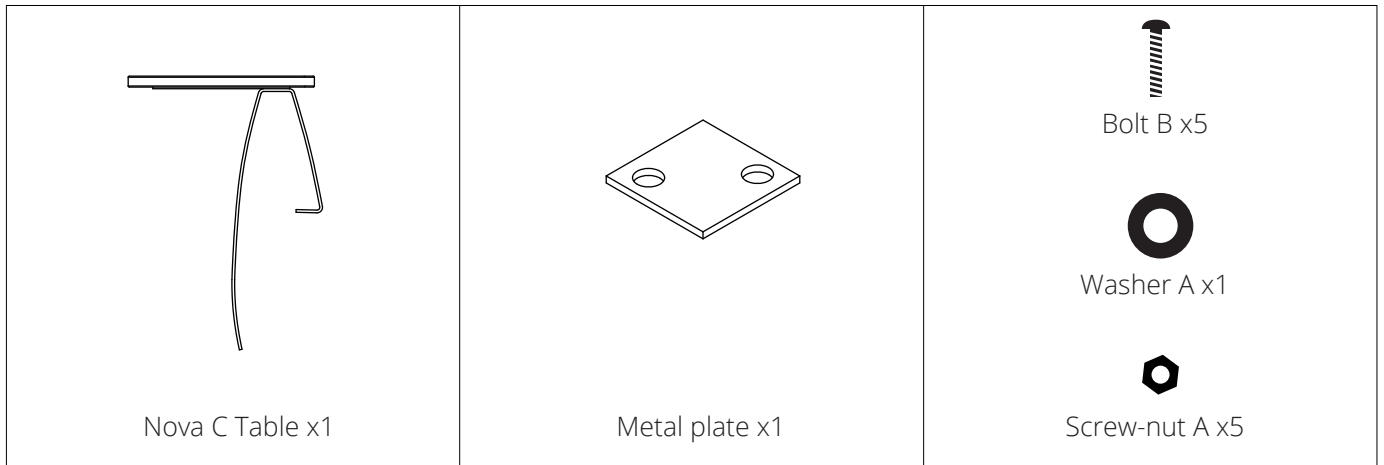



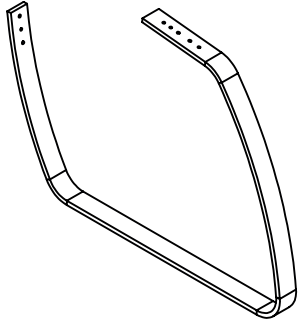
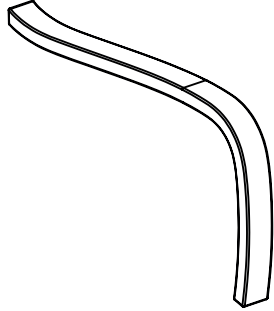
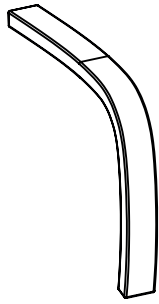
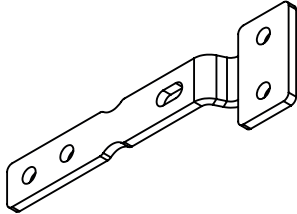
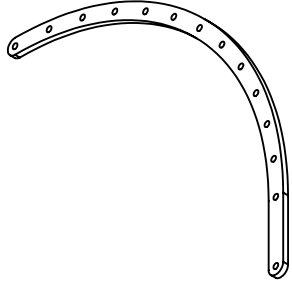
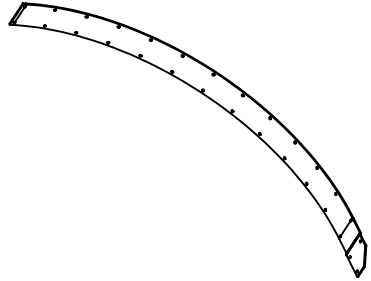
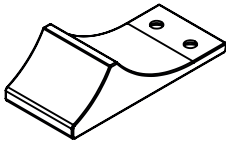
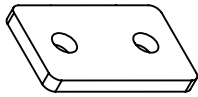
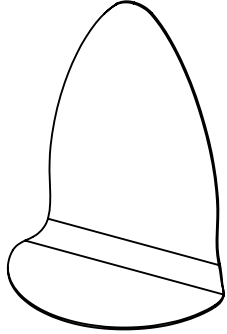
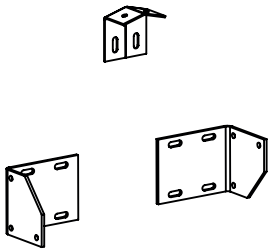
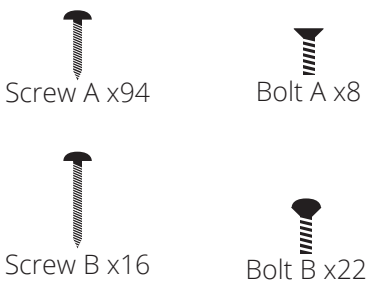

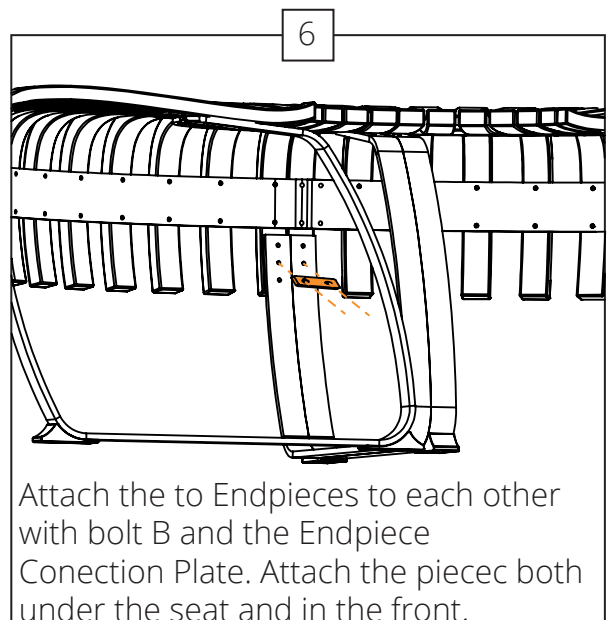
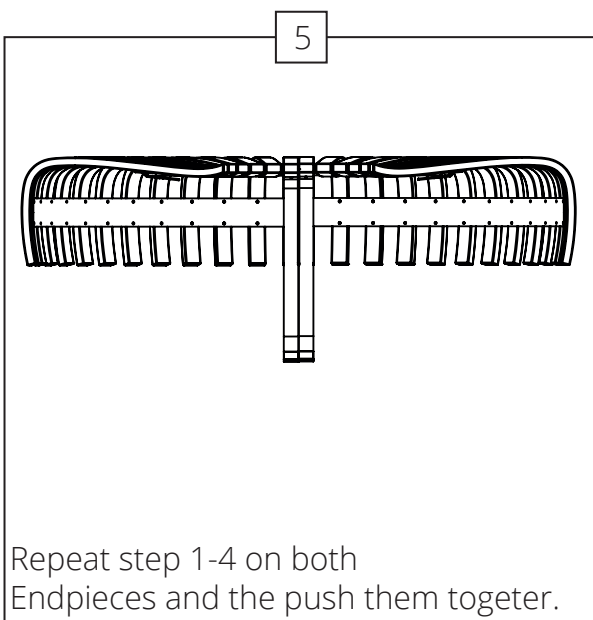
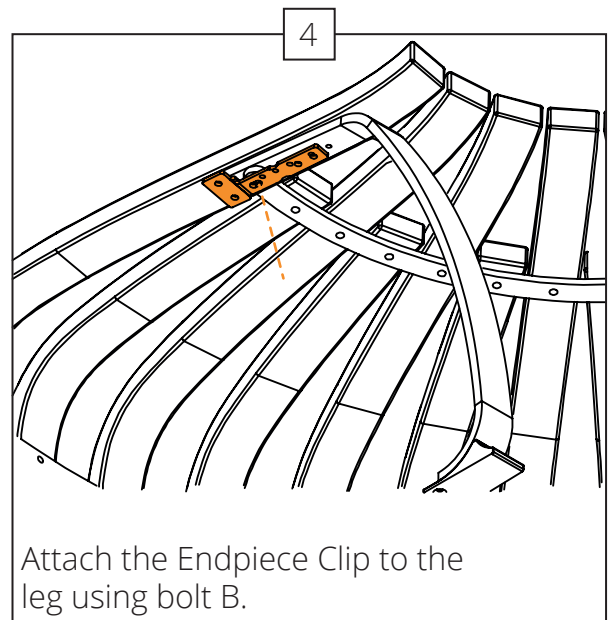
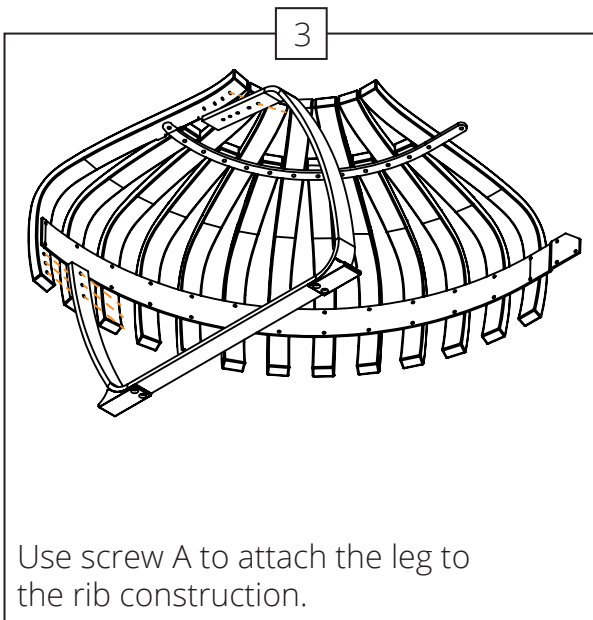
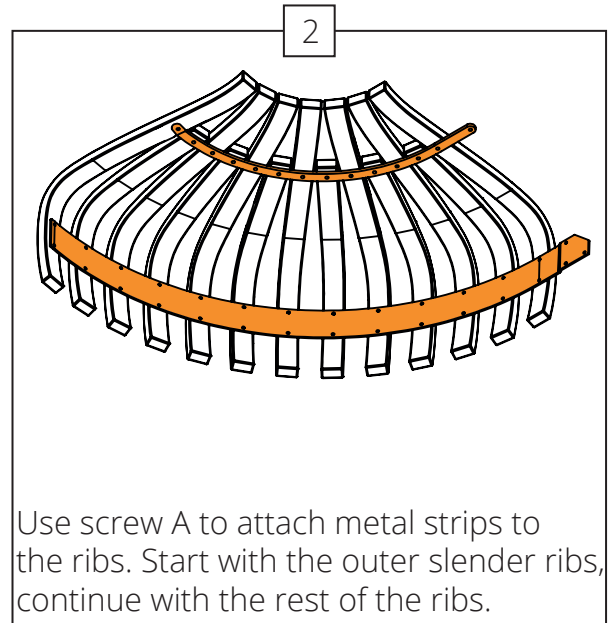
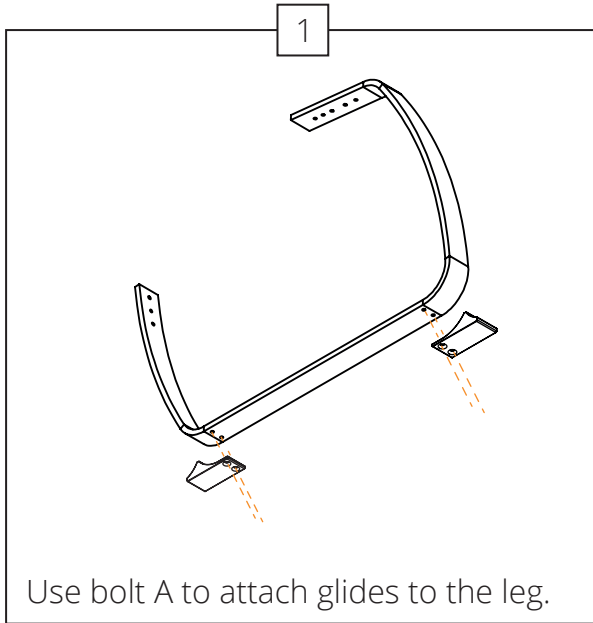

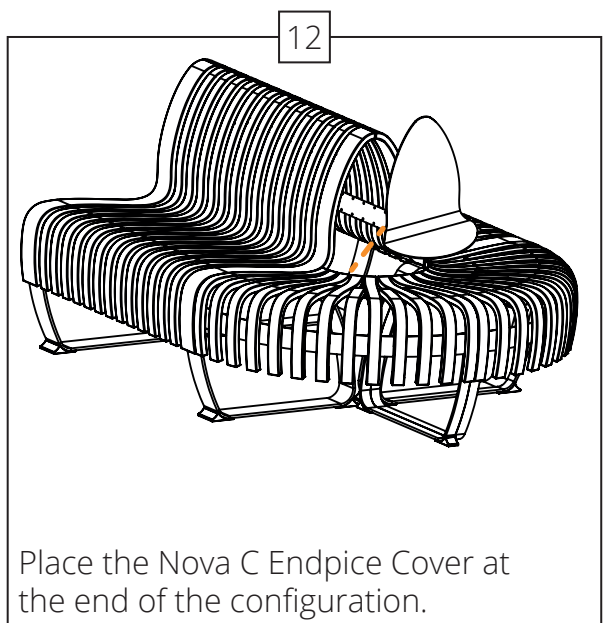
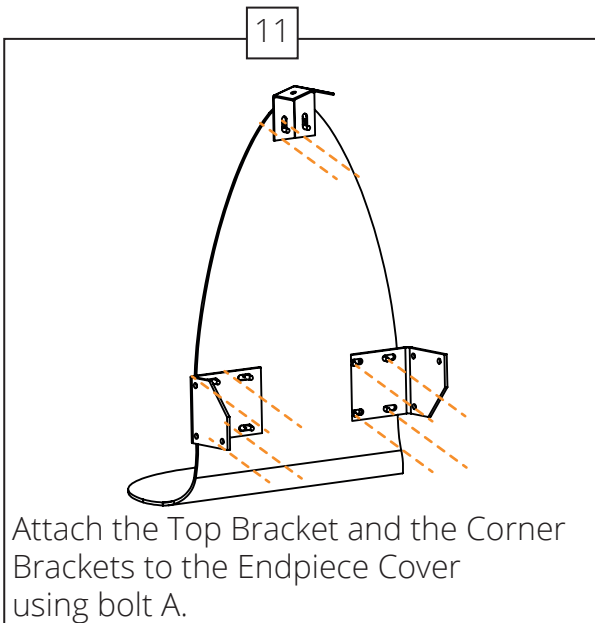
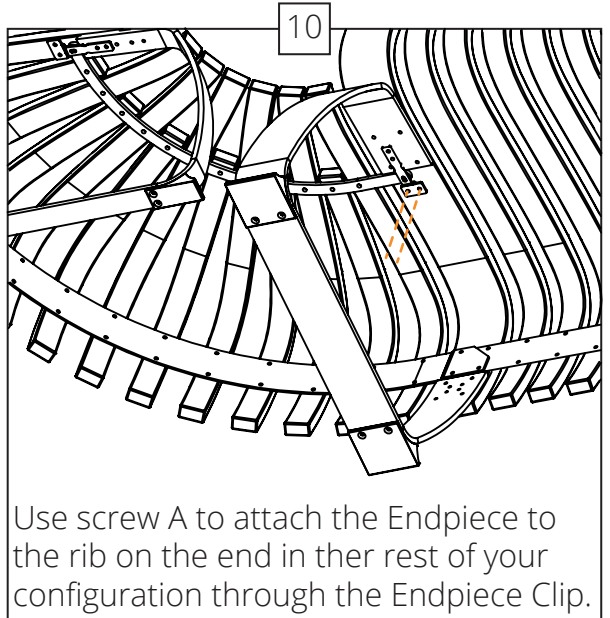
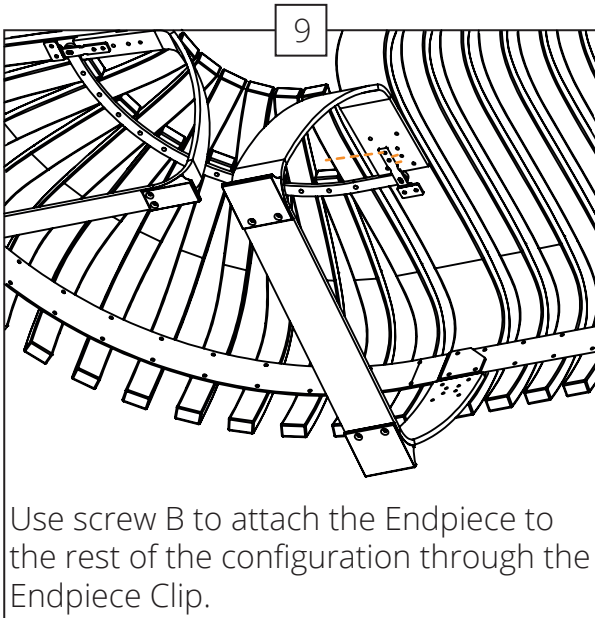
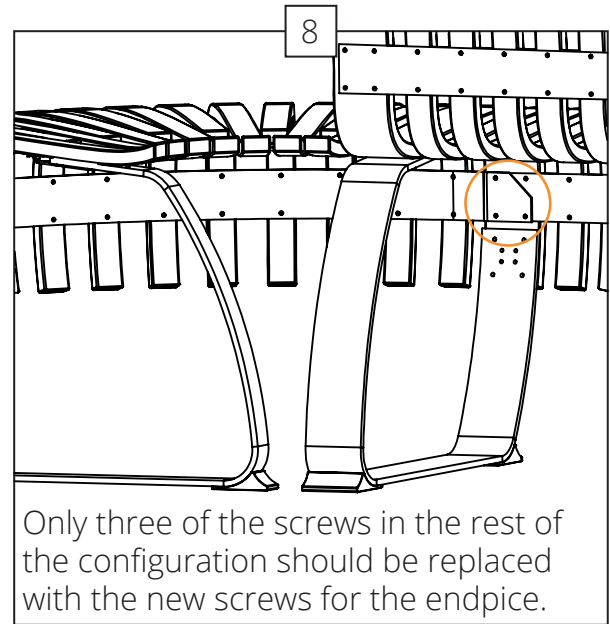
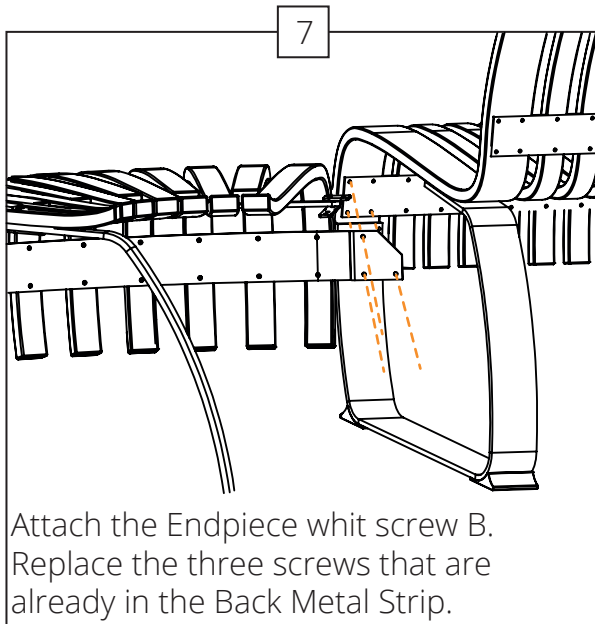
 <p>Nova C Endpiece Leg x2</p>	 <p>Nova C Slender Rib x14</p>	 <p>Nova C Back Half Rib x12</p>
 <p>Nova C Endpiece Clip x4</p>	 <p>Nova C Seat Metal Strip 90 x2</p>	 <p>Nova C Back Metal Strip 90 x2</p>
 <p>Nova C Glides x4</p>	 <p>Nova C Endpiece Connection Plate x2</p>	 <p>Nova C Double Endpiece Cover Plate x1</p>
 <p>Top Bracket x1 Corner Bracket x2</p>	 <p>Screw A x94      Bolt A x8 Screw B x16      Bolt B x22</p>	<p><b>Note:</b> Due to that the assembly of this bench mostly is done with the ribs upside down we recommend you to use a blanket or similar to prevent damage to the ribs and metal parts.</p>

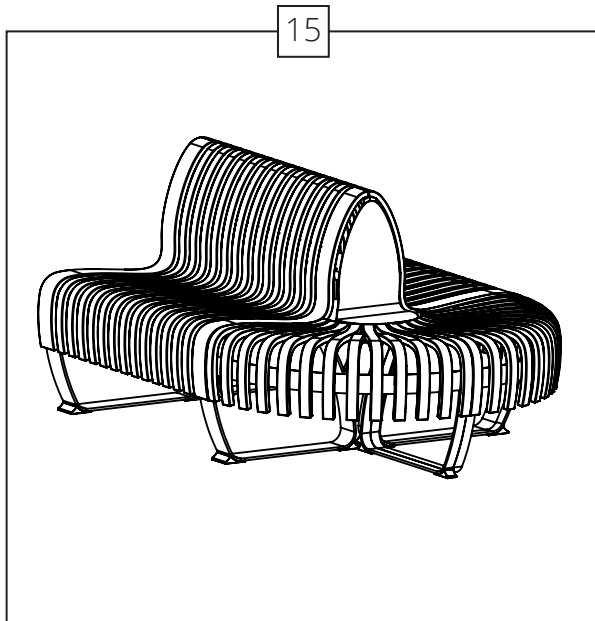
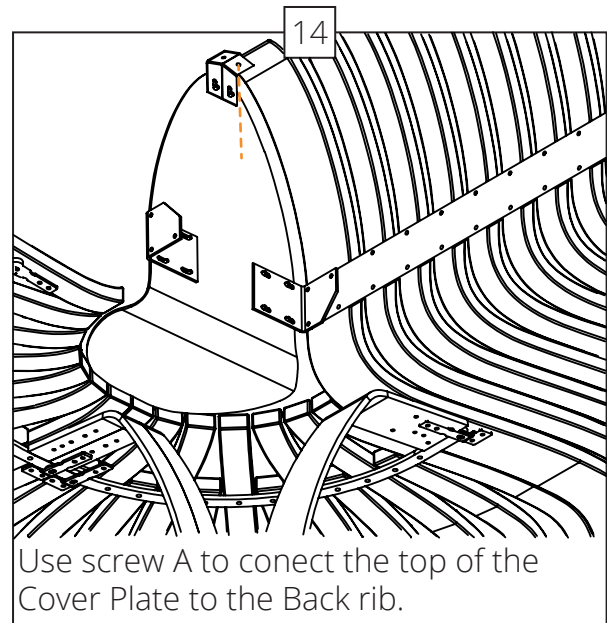
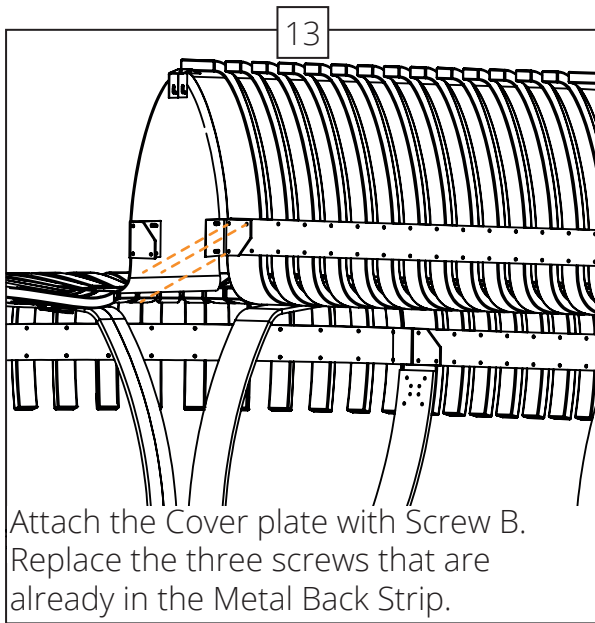

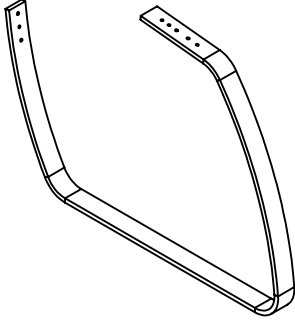
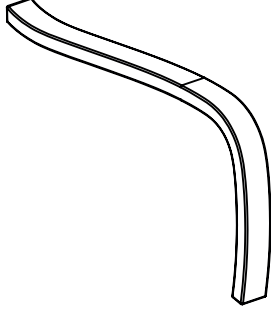
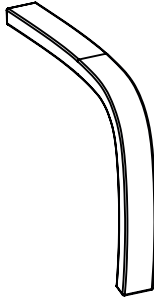
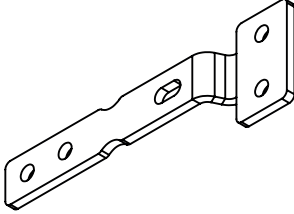
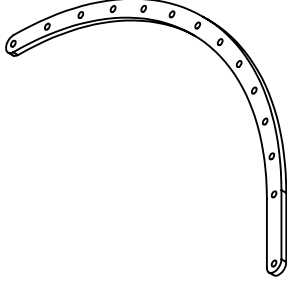
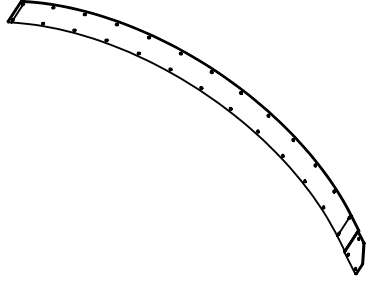
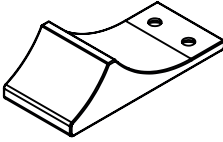
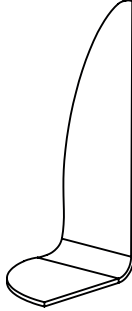
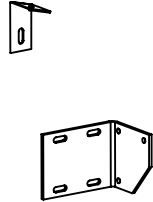



 <p>Nova C Endpiece Leg x1</p>	 <p>Nova C Slender Rib x7</p>	 <p>Nova C Back Half Rib x6</p>
 <p>Nova C Endpiece Clip x1</p>	 <p>Nova C Seat Metal Strip 90 x1</p>	 <p>Nova C Back Metal Strip 90 x1</p>
 <p>Nova C Glides x2</p>	 <p>Nova C Endpiece Cover Plate x1</p>	 <p>Top Bracket x1 Corner Bracket x2</p>
 <p>Screw A x94</p>  <p>Bolt A x8</p>  <p>Screw B x16</p>  <p>Bolt B x22</p>	<p><b>Note:</b> Due to that the assembly of this bench mostly is done with the ribs upside down we recommend you to use a blanket or similar to prevent damage to the ribs and metal parts.</p>	

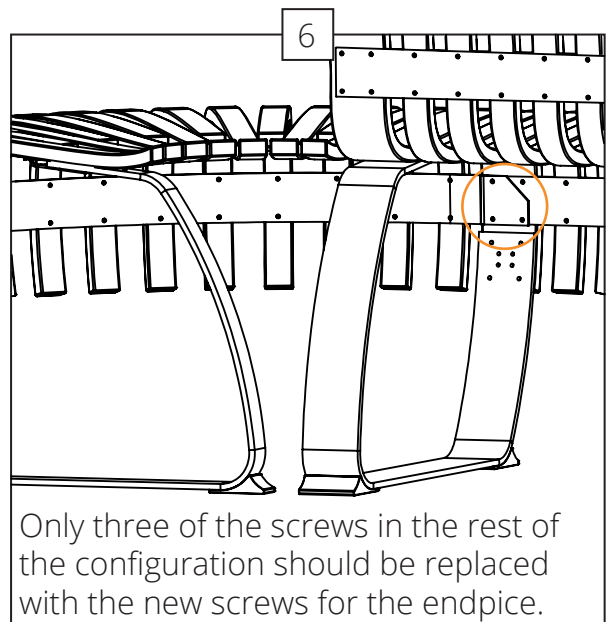
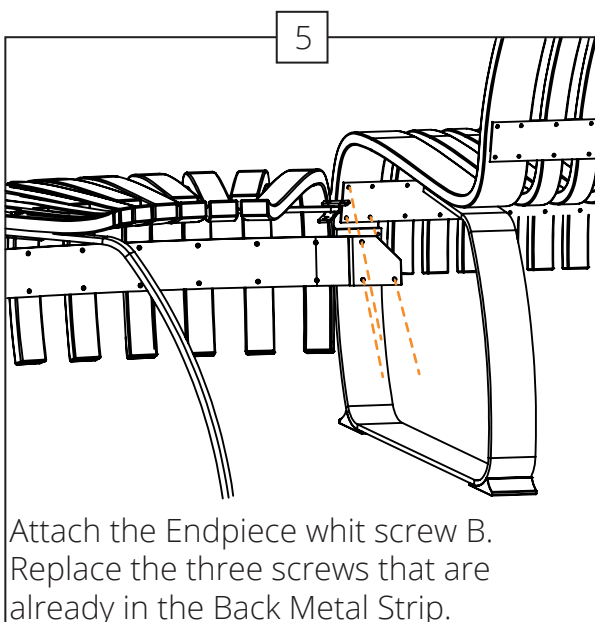
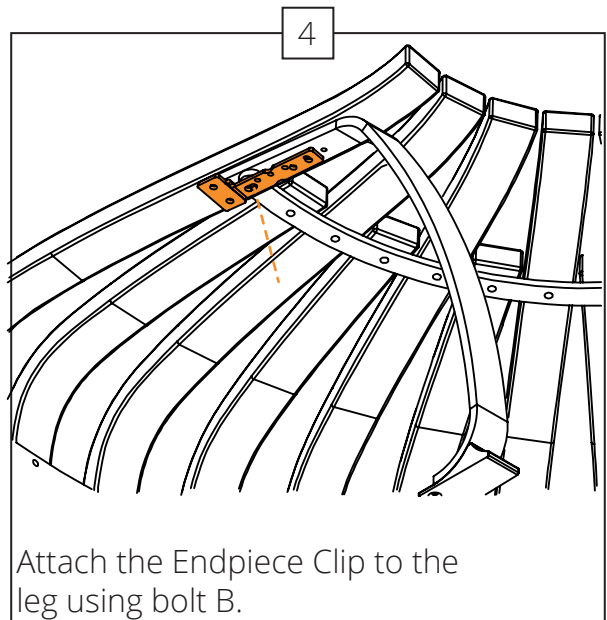
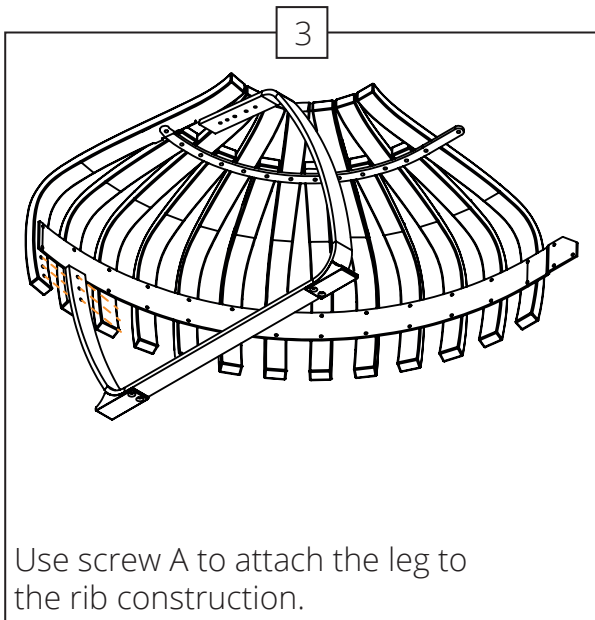
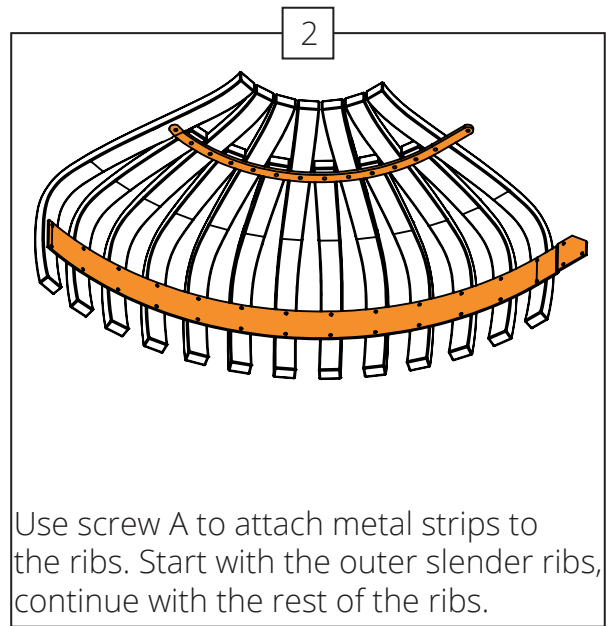
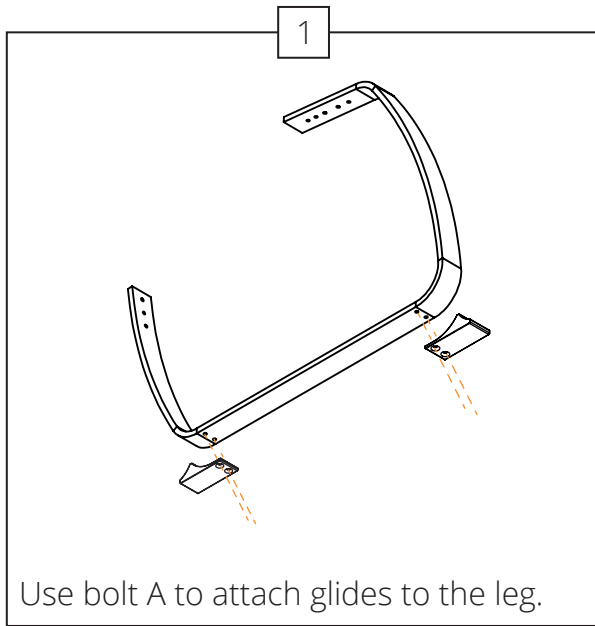

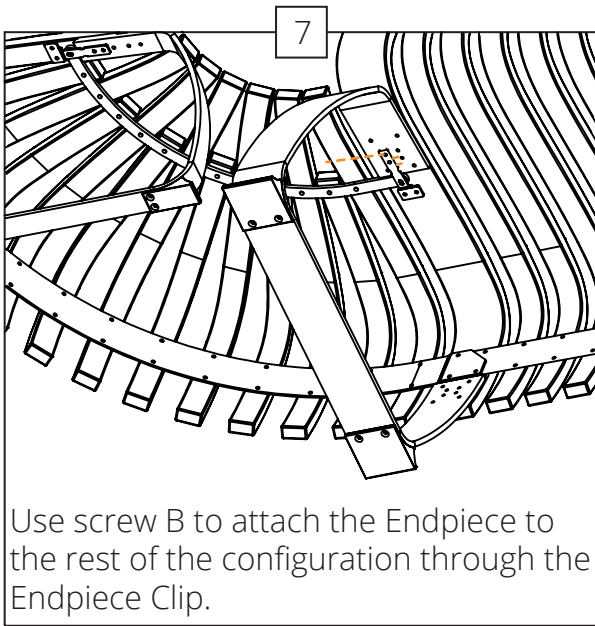

Use screw B to attach the Endpiece to the rest of the configuration through the Endpiece Clip.

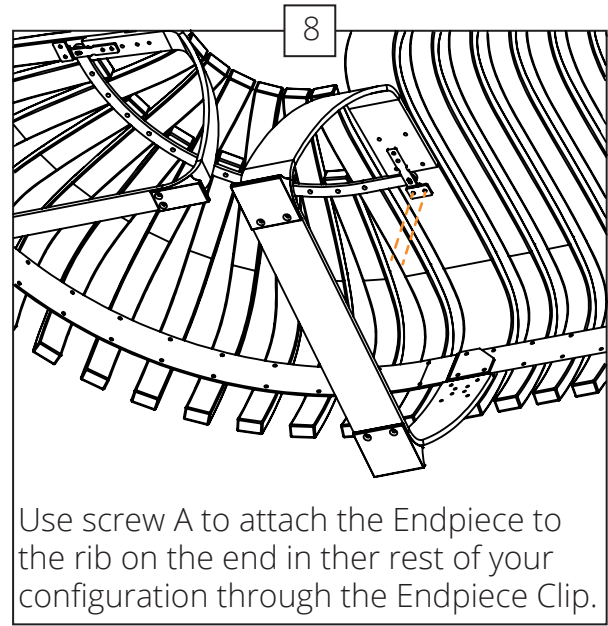

Use screw A to attach the Endpiece to the rib on the end in their rest of your configuration through the Endpiece Clip.

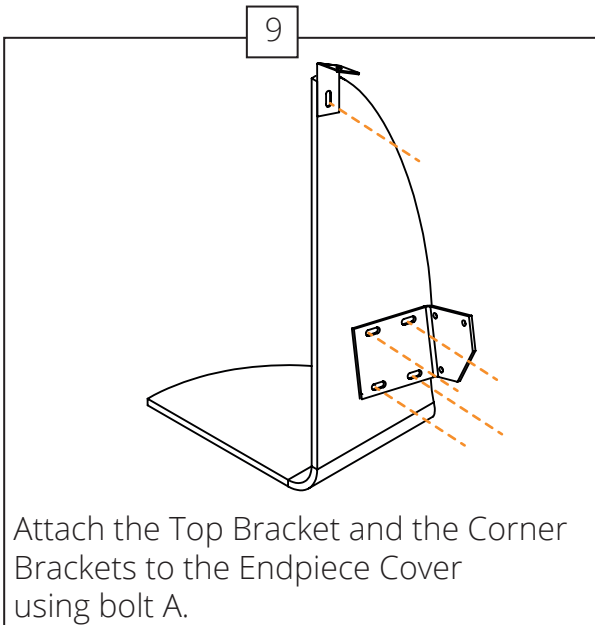

Attach the Top Bracket and the Corner Brackets to the Endpiece Cover using bolt A.

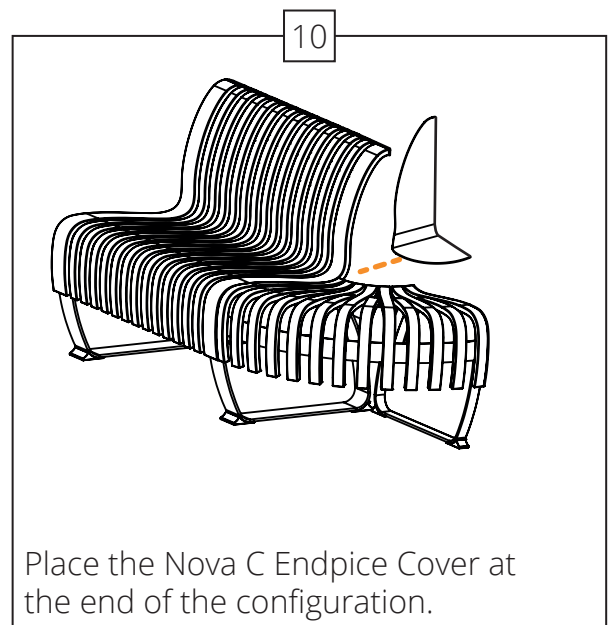

Place the Nova C Endpiece Cover at the end of the configuration.

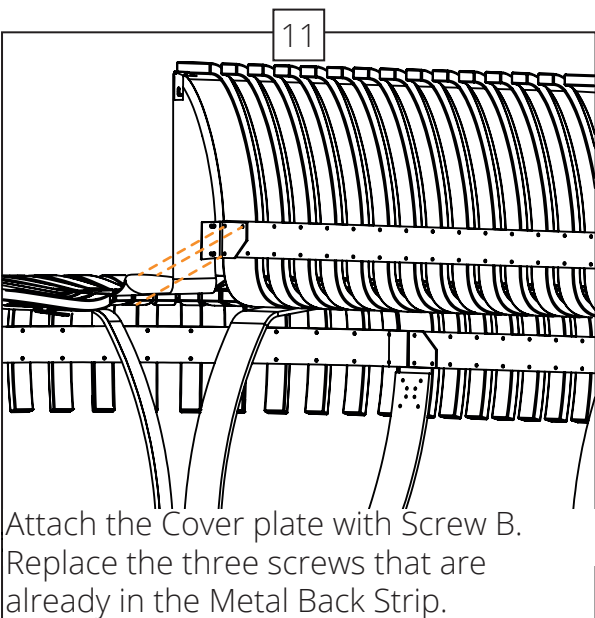

Attach the Cover plate with Screw B. Replace the three screws that are already in the Metal Back Strip.

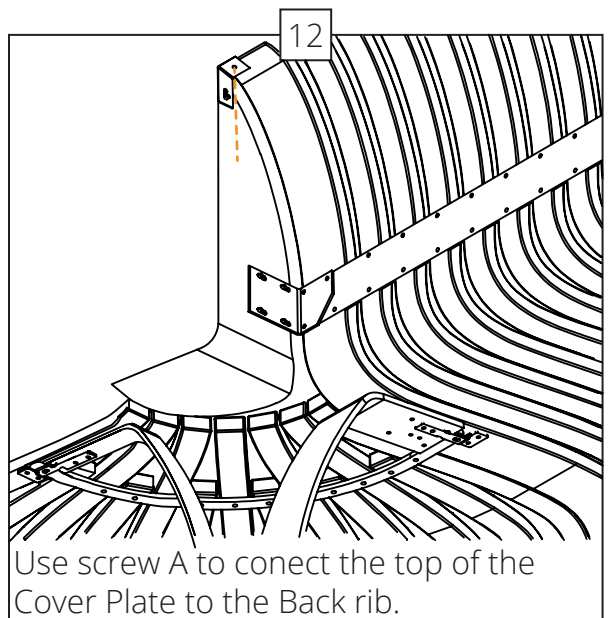

Use screw A to connect the top of the Cover Plate to the Back rib.

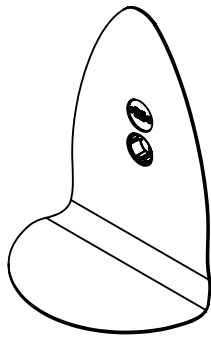

Nova C Endpiece  
Charger Cover Plate x1

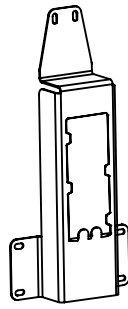

Charger Cover x1

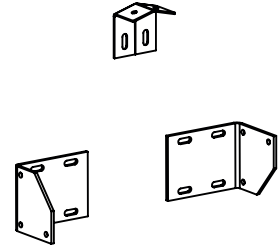

Top Bracket x1  
Corner Bracket x2



Washer A x6



Screw A x2



Screw-nut A x6



Screw B x6

1

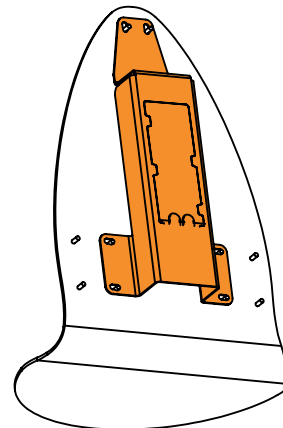

Place the Charger Cover on the  
Cover Plate.

2

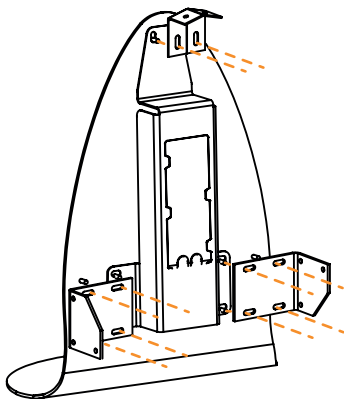

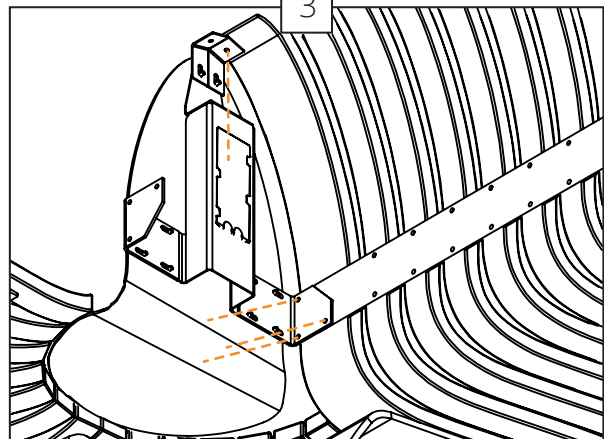

Attach the Top and Corner Brackets to  
the Charger Cover Plate using washer A  
and screw-nut A.

3



Attach the hole assembly to the Nova C  
Endpiece configuration using screw A in  
the Top Bracket and Screw B for the  
Corner Brackets.

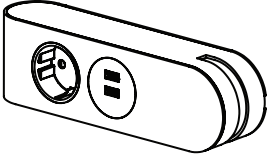
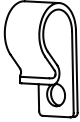
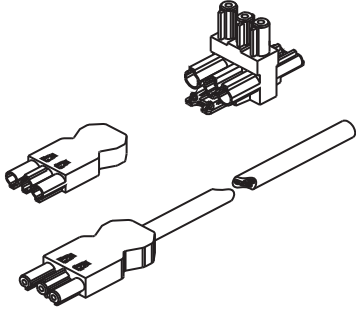

 <p>Charger x1</p>	 <p>Cable clip x7</p>	 <p>Cable kit x1</p>
 <p>Bolt A x4</p>  <p>Screw A x7</p>		

1

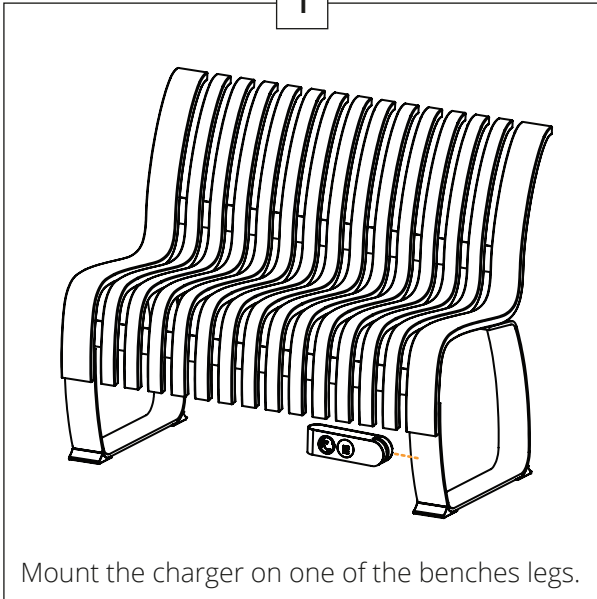

2

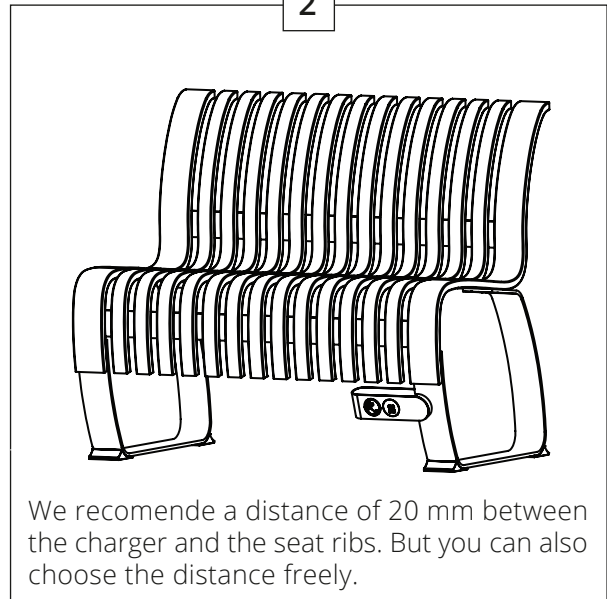

3

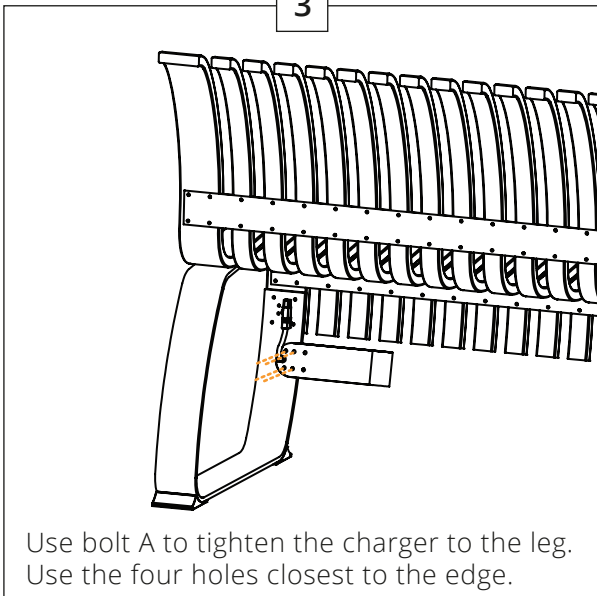

4

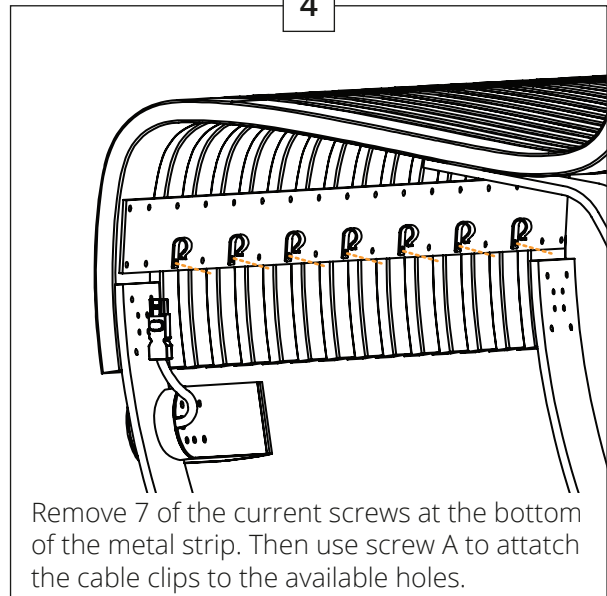

5

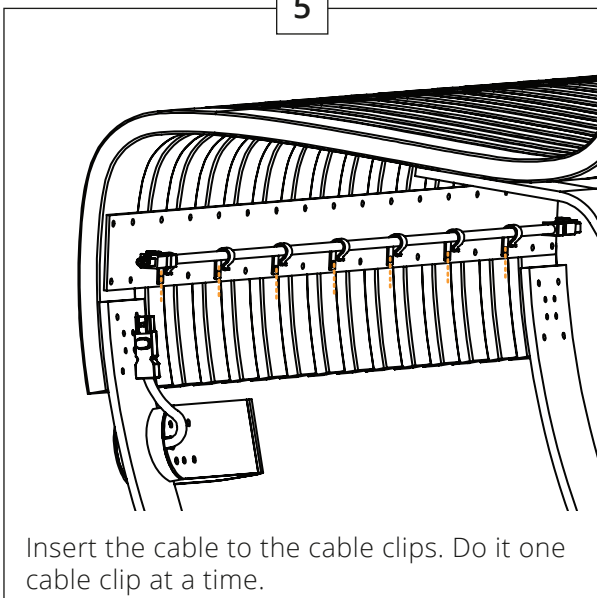

6

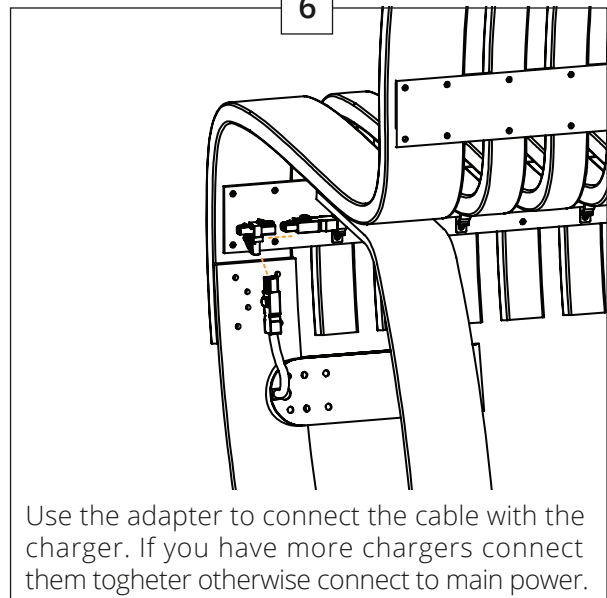



**Radius Charger modularity**

Radius Charger are available in single or double colors and the two outlets can be of any of the modules below.

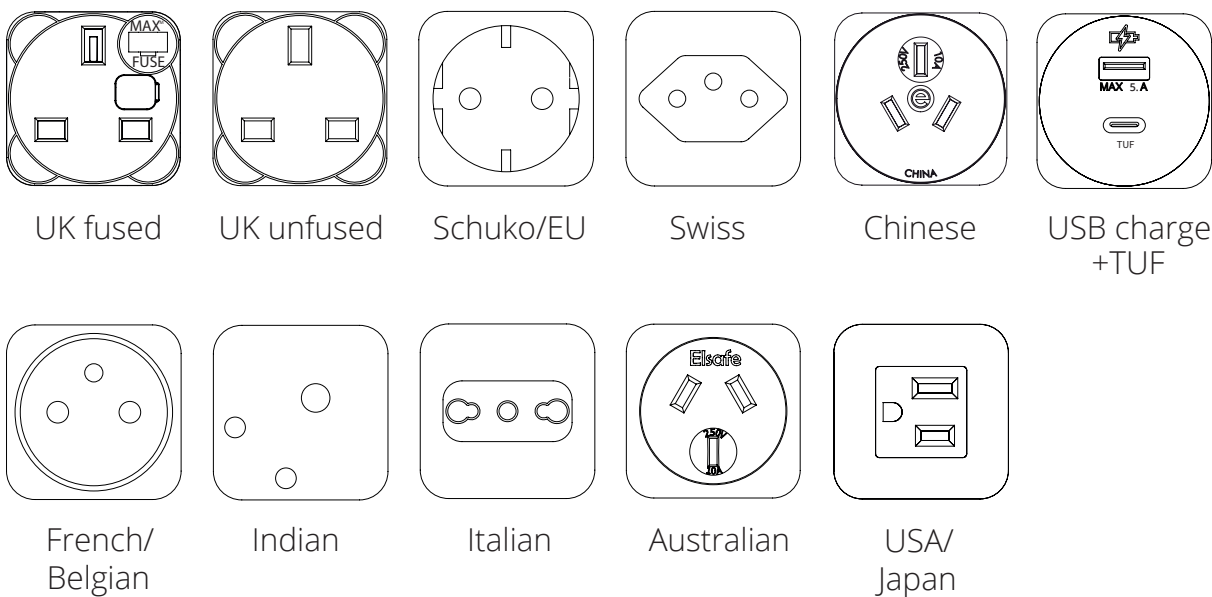

### Nova C Series

Radius charger as single color mounted on Nova C Back



### IOU Series

Radius charger as single color mounted on IOU Back



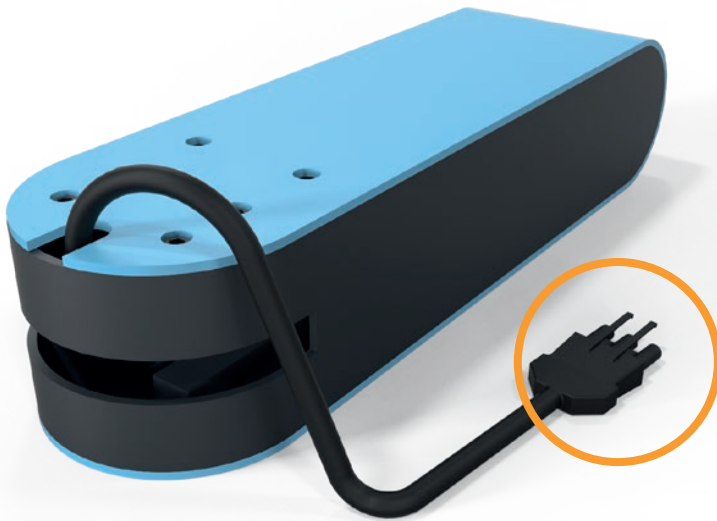

### Wieland Connector

Radius Charger uses a Wieland connector cable to be able to link more than one charger to one electricity source. The cable comes out from the back of Radius Charger as the image to the left shows. The length of the cable is 300mm by standard but can be made with a custom length if needed..

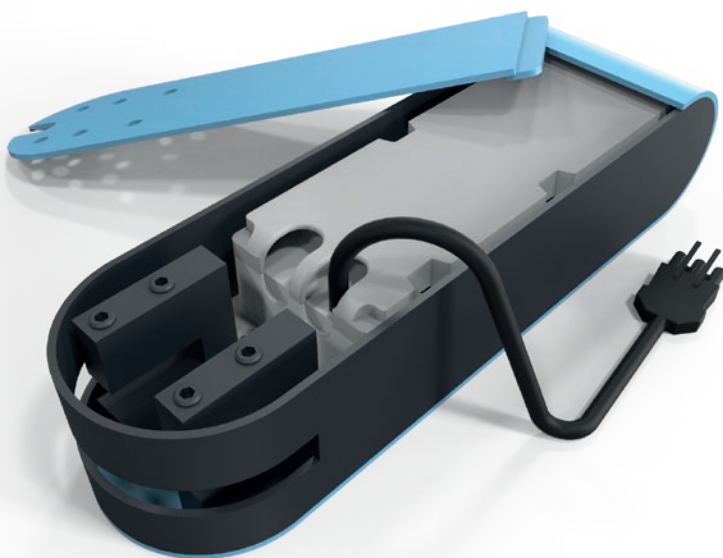

### Electric component

Radius Charger uses a power socket with re-inforced insulation that is CE marked and certified with UL962A/CSA22.2 and UL1363. Both the power socket and its two outlets can be changed easily if needed.

### Radius Charger assembly

To assemble Radius Charger onto a Nova C Series or IOU Series Bench slide the charger onto the leg, tighten the four screws and connect the power cable.

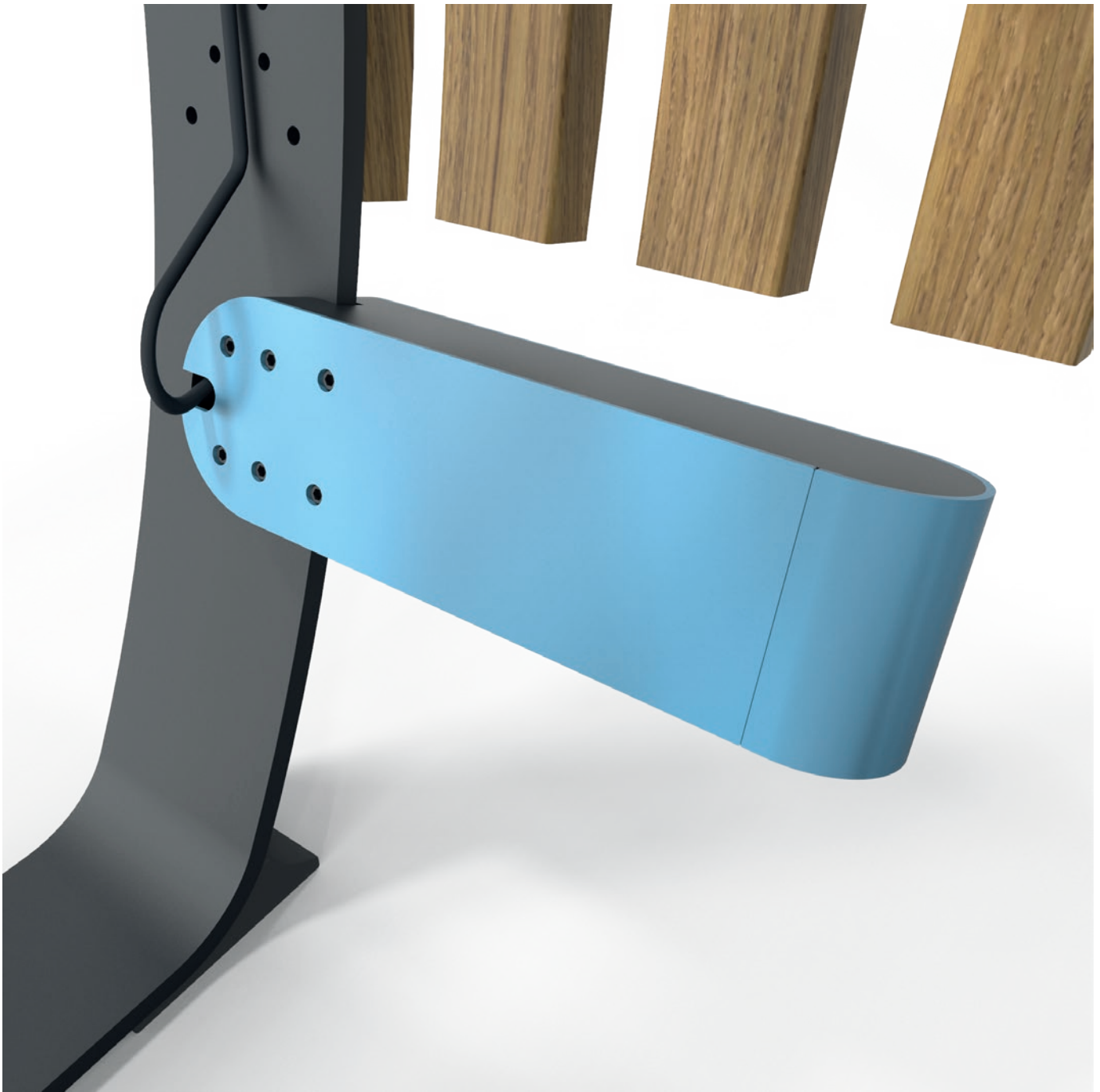

**Radius Charger Connecting Cables**

When connecting Radius Charger to your electricity source, you will need the following parts.  
Important! Always shut off power to the circuit before starting installation work. In some countries electrical installation work may only be carried out by a authorised electrical contractor. Contact your local electricity authority for advice.

**Radius Charger**

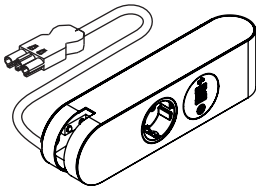

1 x Radius Charger (Green)

**Starter Cable (Standard: 1 cable per configuration)**

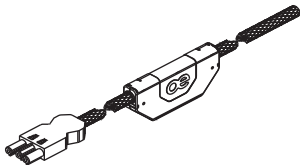

1 x Starter Cable (Orange)

**Cable Kit (Standard: 1 kit per bench)**

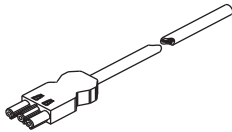

1 x Interconnector Cable (Yellow)

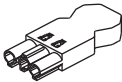

1 x Slimline Male Wieland (Red)

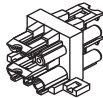

1 x Wieland Adaptor Block (Purple)



4 x Cable Clip (Blue)

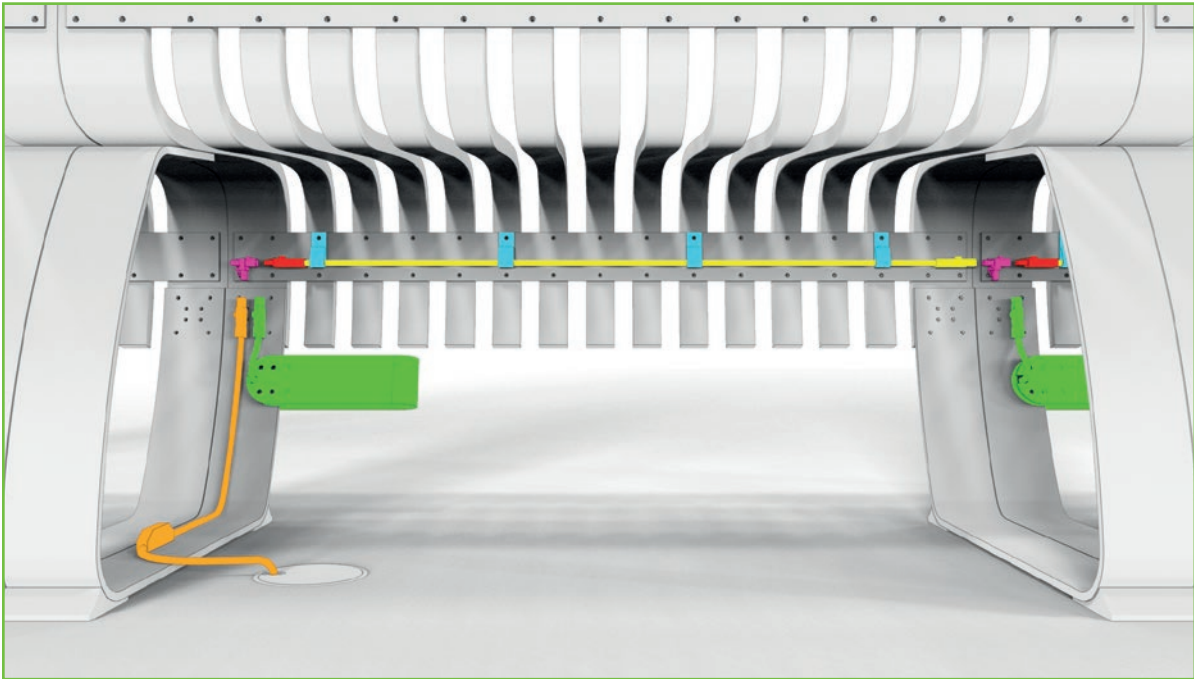

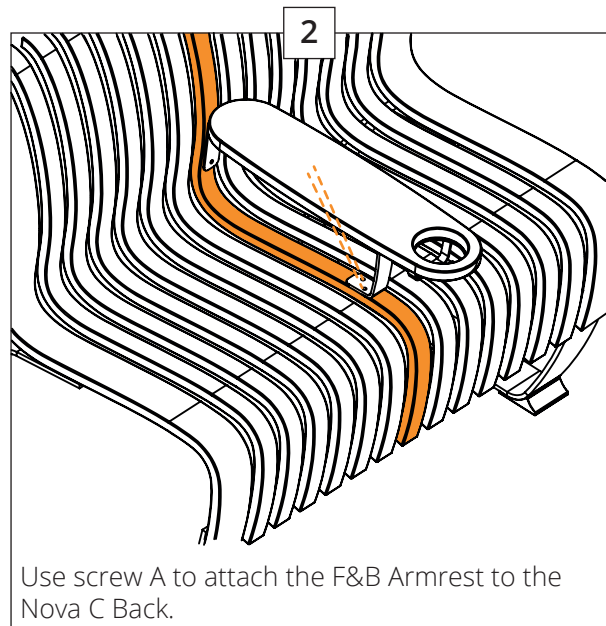
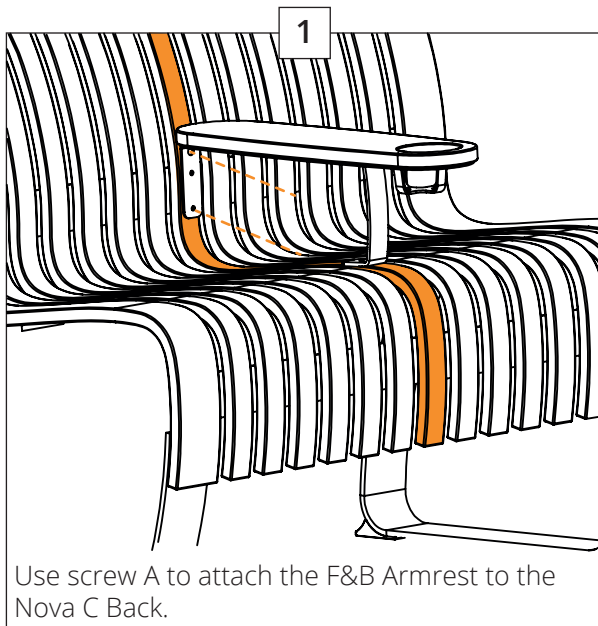
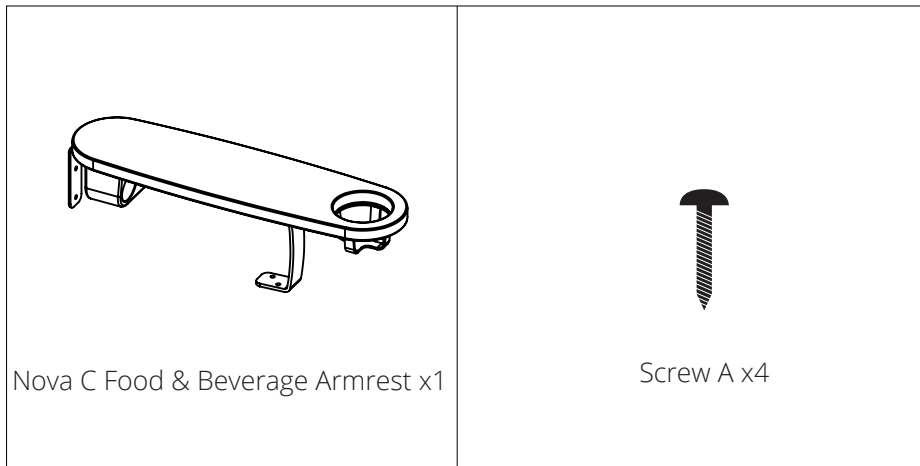





### Food & Beverage Armrest Charger modularity

The two outlets can be of any of the modules below.

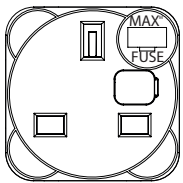

UK fused

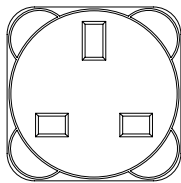

UK unfused

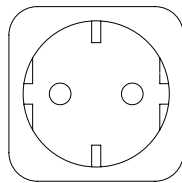

Schuko/EU

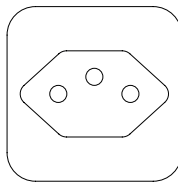

Swiss

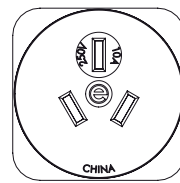

Chinese

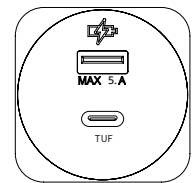

USB charge  
+ TUF

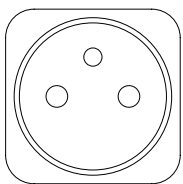

French/  
Belgian

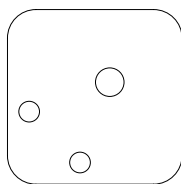

Indian

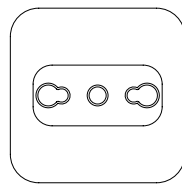

Italian

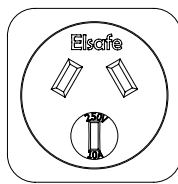

Australian

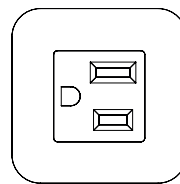

USA/  
Japan



## Food & Beverage Armrest Charger

Charger Armrest used om Nova C.





### Wieland Connector

Food & Beverage Armrest Charger uses a Wieland connector cable to be able to link more than one charger to one electricity source. The cable comes out from the back of F&B Charger as the image to the left shows. The length of the cable is 300mm by standard but can be made with a custom length if needed..

F&B Armrest Charger uses a power socket with re-inforced insulation that is CE marked and certified with UL962A/CSA22.2 and UL1363. Both the power socket and its two outlets can be changed easily if needed.

### Food & Beverage Armrest Charger Connecting Cables

When connecting F&B Armrest Charger to your electricity source, you will need the following parts. Important! Always shut off power to the circuit before starting installation work. In some countries electrical installation work may only be carried out by a authorised electrical contractor. Contact your local electricity authority for advice.

#### F&B Armrest Charger

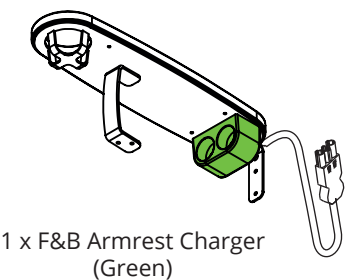

1 x F&B Armrest Charger (Green)

#### Starter Cable (Standard: 1 cable per configuration)

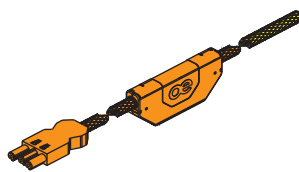

1 x Starter Cable (Orange)

#### Cable Kit (Standard: 1 kit per bench)

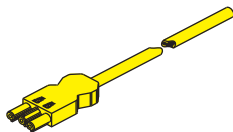

1 x Interconnector Cable (Yellow)

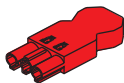

1 x Slimline Male Wieland (Red)

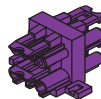

1 x Wieland Adaptor Block (Purple)



4 x Cable Clip (Blue)

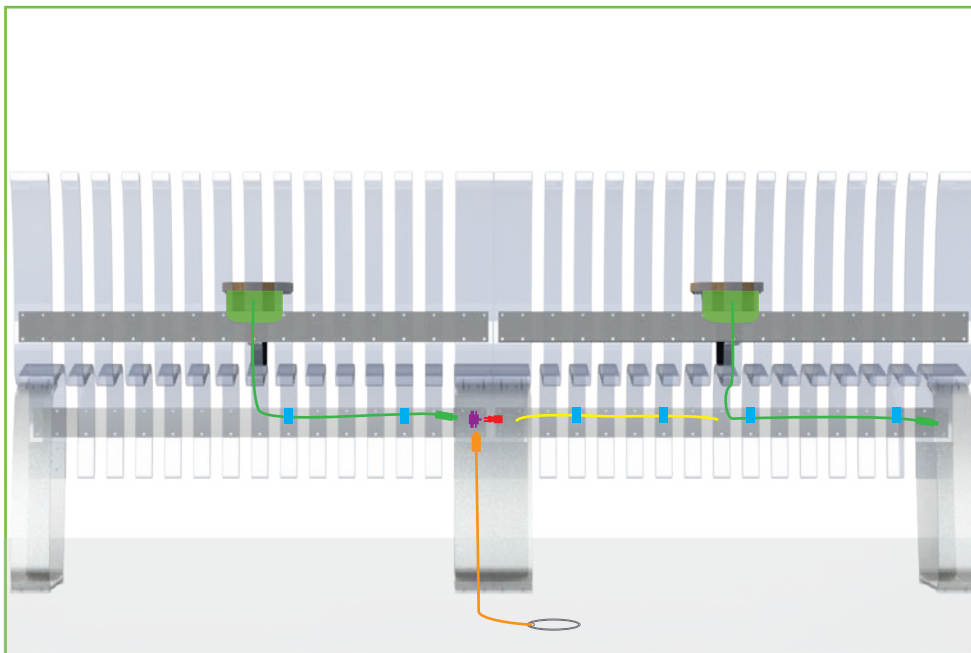

### Food & Beverage ArmrestCharger assembly

To assemble Food and Beverage Armrest Charger onto a Nova C Series Bench, screw in the Armrest in to the bench with the included screws and connect the power cable.

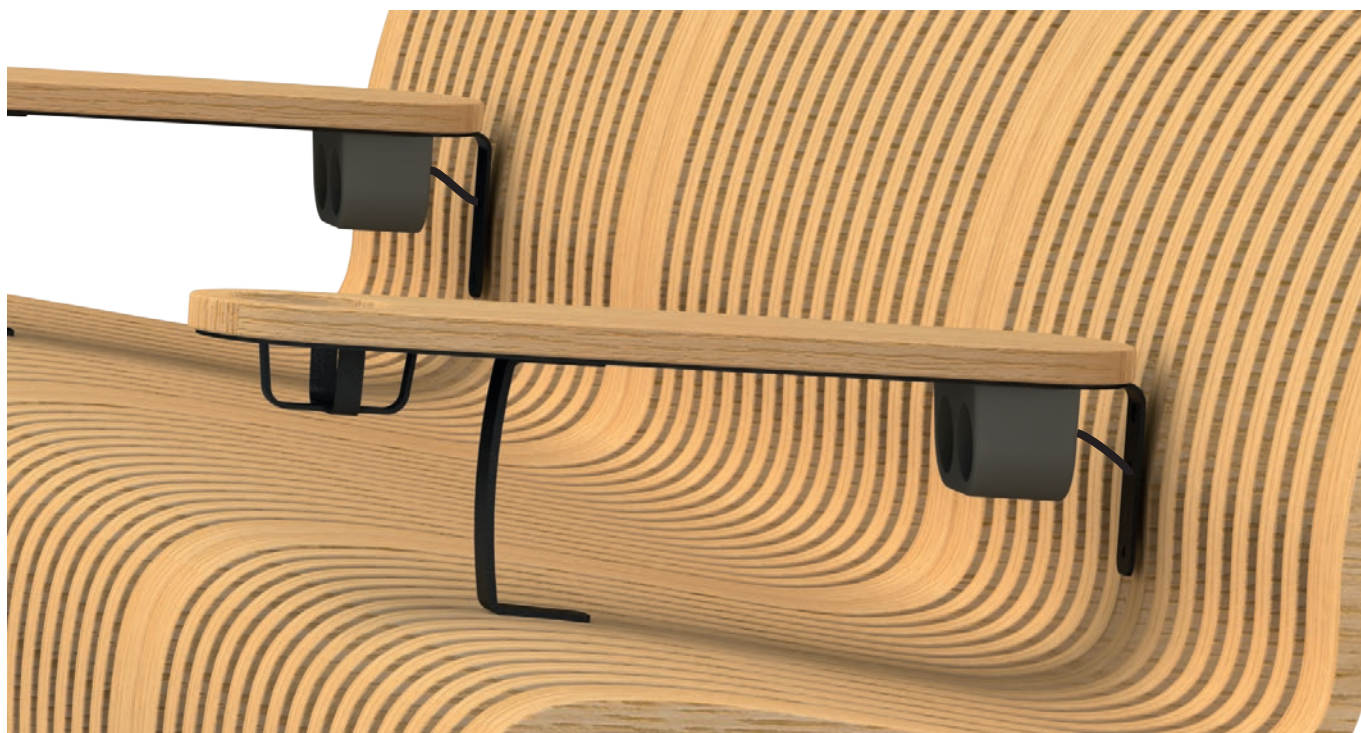

The cable should go through the back plate of the armrest and through the wooden rib.

G

Green Furniture Concept